

No.	F084-3714
ISSUED:	Jun. 11, 2012
REVISED:	Apr. 1, 2013



HOSHIZAKI
MODULAR ICE MAKER

MODEL FM-170AKE(-N)
(F084, F084-C106)

PARTS LIST

B-1 JUN. 2012
C-0 JAN. 2013
C-1 APR. 2013

AUXILIARY CODE

U - 1

The auxiliary code is the first two characters in the serial number. The first character indicates the production year. Years progress or regress in alphabetical order. The series of letters and skipped letters depend on UL listing, production, and model. See the auxiliary code(s) and corresponding year(s) on the front cover.

The second character indicates significant part changes within the same year. Base is "1" and this number advances for each change. If there is no significant part change at the turn of the year, this number starts from "0."

MARKS LOCATED UNDER THE AUXILIARY CODE

- = Part deleted.
- x = Part deleted and replaced by "o" part.
- o = New part in place of "x" part.

FASTENER PART NUMBER

SCREWS



*¹ Material

- F: Steel
- S: Austenitic stainless steel
- M: Martensitic stainless steel
- B: Copper alloy
- P: Polycarbonate
- N: Polyamide
- V: PVC
- A: ABS
- X: Polyacetal
- L: Aluminum

NUTS & WASHERS

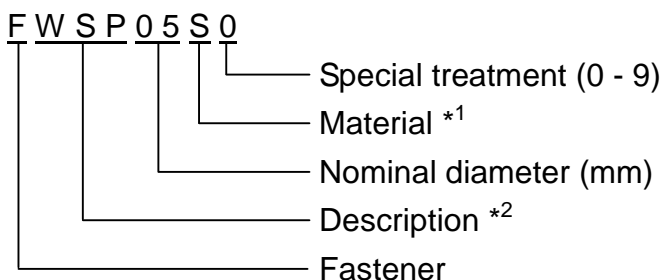

*² Description

- First letter
- S: Machine screw
- T: Tapping screw
- M: Wood screw
- B: Bolt
- W: Washer
- N: Nut

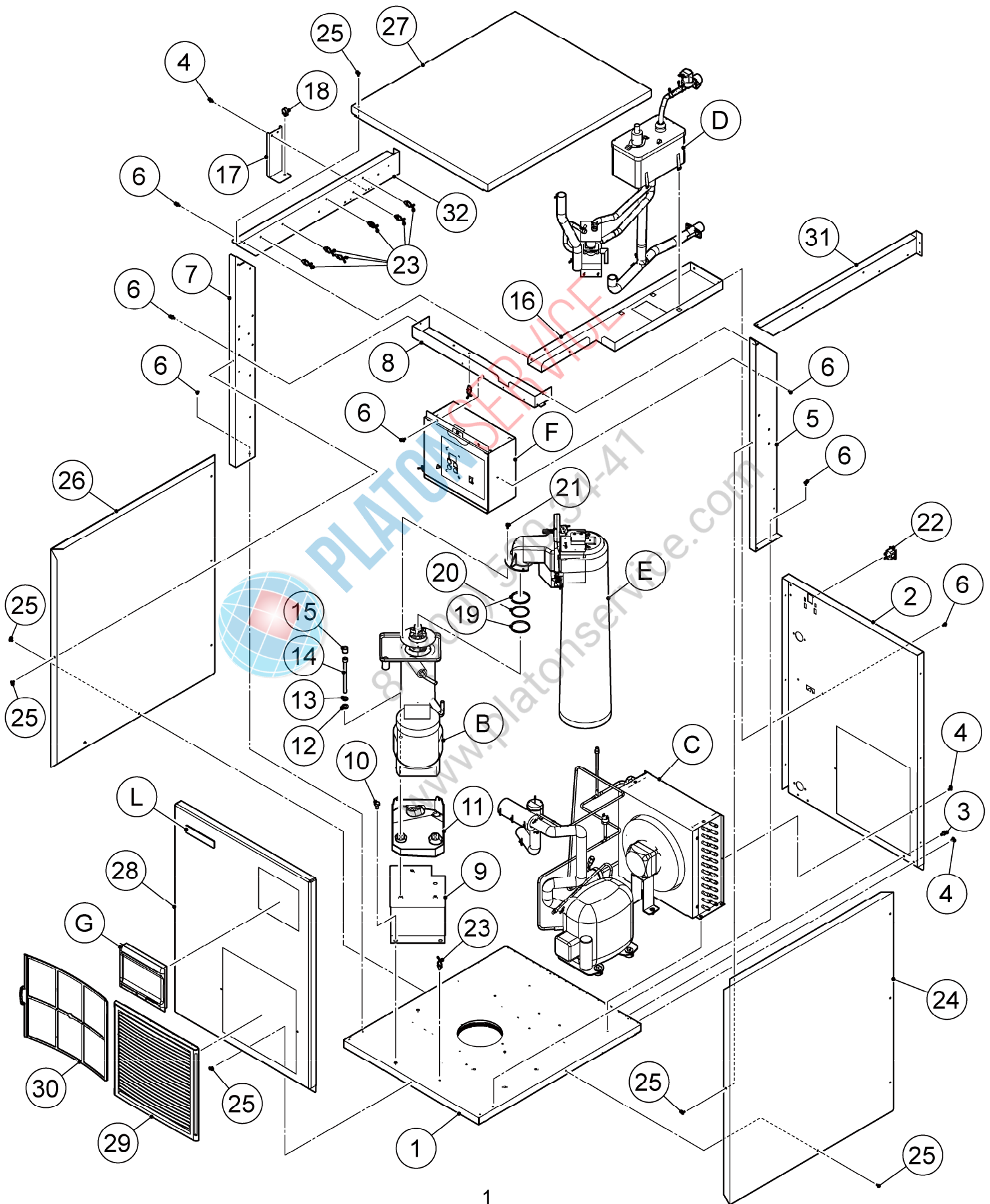

HE

MODEL: FM-170AKE(-N)				TITLE: A. ICE FLAKER ASSY			
INDEX NO.	DESCRIPTION	MATERIAL OR MODEL NUMBER	PART NUMBER	REQ'D NUMBER			
				B-1 C-0	C-1		
B	ICE MAKING UNIT		377263A01	1	1		
		NUGGET F084-C106	377263001	1	1		
C	REFRIGERATION CIRCUIT		122268A01	1	1		
D	WATER CIRCUIT		122269A01	1	1		
E	CHUTE UNIT	(S-20288)	253526A01	1	1		
F	CONTOROL BOX ASSY		263373A01	1	1		
G	WINDW PANEL ASSY		348243A03	1	1		
H	LABEL LOCATION		263375A01	1	1		
		F084-C106	263375A02	1	1		
N	ACCESSORIES		A02524-01	1	1		
1	CHASSIS		122266G01	1	1		
2	REAR PANEL		122272M01	1	1		
3	HEX HEAD BOLT (SPRING WASHER AND FLAT WASHER)		FBK0512S0	2	2		
4	T2 TRUSS HEAD SCREW		FT20408F0	6	6		
5	SIDE FRAME (R1)		264212M01	1	1		
6	TRUSS HEAD MACHINE SCREW		FST0408F0	19	19		
7	SIDE FRAME (L1)		264214M01	1	1		
8	FRONT FRAME		261984M01	1	1		
9	BRACKET-GEAR MOTOR		377262G01	1	1		
10	HEX HEAD BOLT		FBH0812S0	3	3		
11	DRAIN PAN		261640P01	1	1		
12	FLAT WASHER		FWPL08S0	3	3		
13	SPRING WASHER		FWSP08S0	3	3		
14	HEXAGON SOCKET HEAD CAP SCREW		461285-01	3	3		
15	VINYL CAP		451272-01	3	3		
16	BRACKET-RESERVOIR		253041M01	1	1		

HE

MODEL: FM-170AKE(-N)		TITLE: A. ICE FLAKER ASSY					
INDEX NO.	DESCRIPTION	MATERIAL OR MODEL NUMBER	PART NUMBER	REQ'D NUMBER			
				B-1 C-0	C-1		
17	BRACKET-PIPE		477648M01	1	1		
18	CLAMP		428644-03	1	1		
19	RING		432661-03	2	2		
20	O-RING		7616-G045	1	1		
21	HEX HEAD BOLT (SPRING WASHER AND FLAT WASHER)		FBK0412S0	3	3		
22	CONNECTOR		P00245-02	1	1		
23	WIRE RETAINER	No.249	427902-03	7	7		
24	SIDE PANEL (R)		262071M01	1	1		
25	TRUSS HEAD SCREW		FST0408S0	12	12		
26	SIDE PANEL (L)		261989M01	1	1		
27	TOP PANEL		261991M01	1	1		
28	FRONT PANEL (A)		122243G01	1	1		
29	LOUVER		121931P01	1	1		
30	AIR FILTER		262259G01	1	1		
31	SIDE FRAME (R2)		264213M01	1	1		
32	SIDE FRAME (L2)		264215M01	1	1		

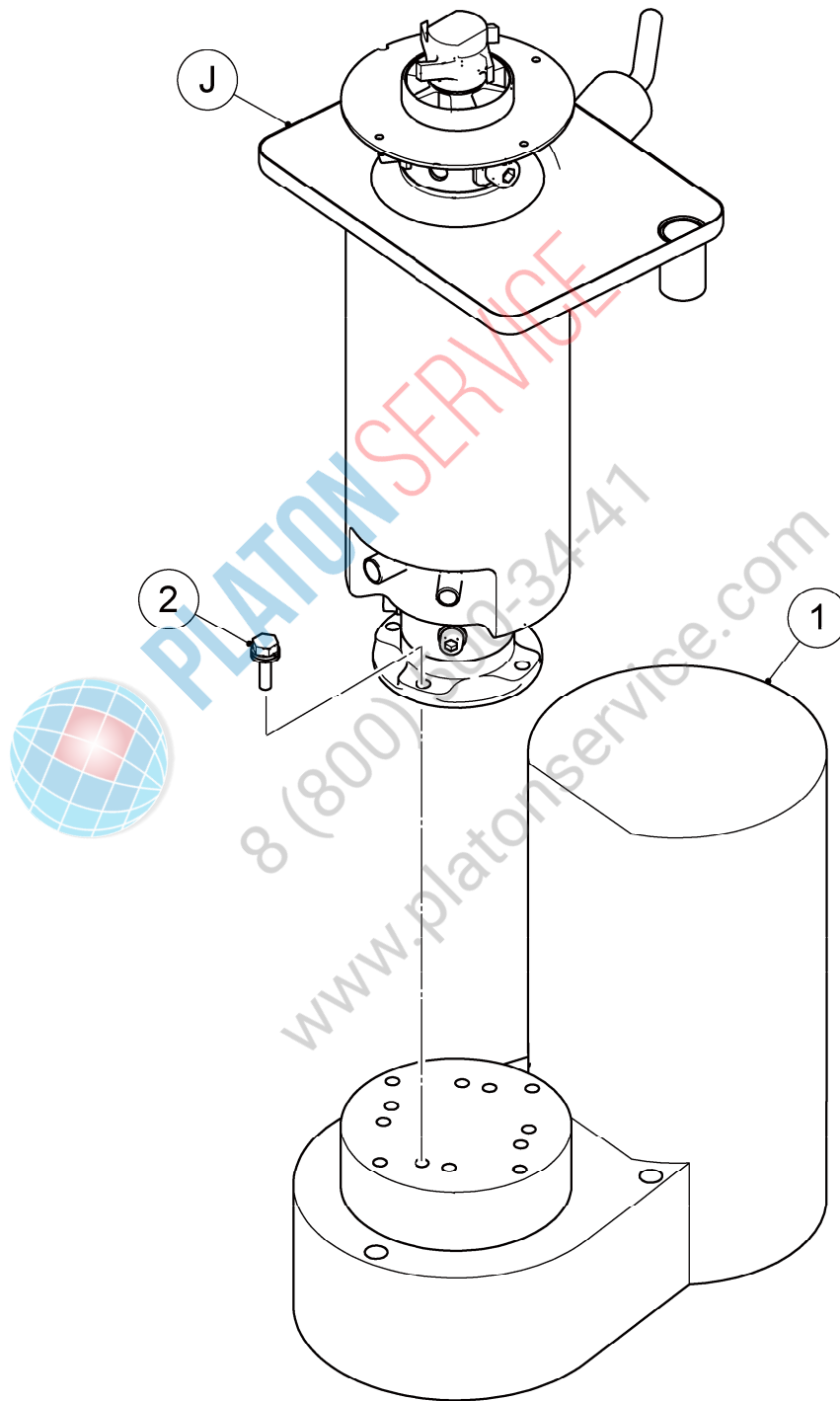

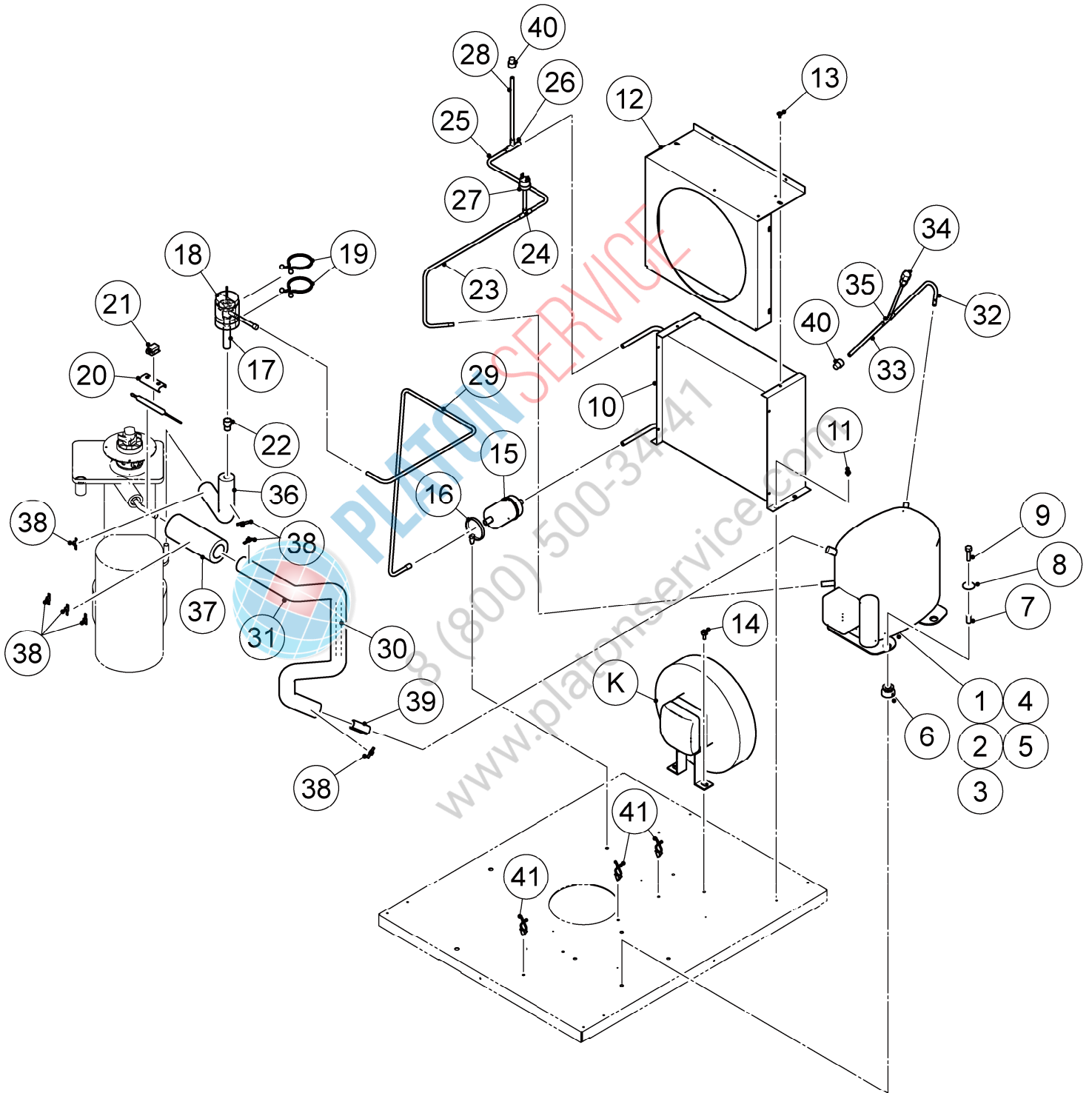

HE

MODEL: FM-170AKE(-N)				TITLE: C. REFRIGERATION CIRCUIT			
INDEX NO.	DESCRIPTION	MATERIAL OR MODEL NUMBER	PART NUMBER	REQ'D NUMBER			
				B-1 C-0	C-1		
K	FAN MOTOR ASSY		377264A01	1	1		
1	COMPRESSOR	SC18GX	452236-01	1	1		
2	STARTING CAPACITOR	117U5019 CM ACCESSORIES	456350-01	1	1		
3	START RELAY	117U6019 CM ACCESSORIES	452237-01	1	1		
4	CORD RELIEF	103N1004 CM ACCESSORIES	452239-01	1	1		
5	COVER	103N2009 CM ACCESSORIES	459924-01	1	1		
6	RUBBER GROMMET	118-3655 CM ACCESSORIES	4A1452-01	4	4		
7	SLEEVE	112-2052 CM ACCESSORIES	4A1451-01	4	4		
8	WASHER	112-2053 CM ACCESSORIES	4A1450-01	4	4		
9	BOLT	681x1130 CM ACCESSORIES	4A1459-01	4	4		
10	CONDENSER-AIR COOLED		P02264-01	1	1		
11	TRUSS HEAD SCREW		FST0408F0	4	4		
12	SHROUD		3Y6035M01	1	1		
13	T2 SCREW	4x8	FT20408F0	6	6		
14	HEX,HEAD BOLT	SUS 6x12	FBH0612S0	2	2		
15	DRIER	DML032.5s	462965-01	1	1		
16	TIE		436156-02	1	1		
17	EXPANSION VALVE		446808-01	1	1		
18	VALVE COVER		3Y3196P01	1	1		

HE

MODEL: FM-170AKE(-N)				TITLE: C. REFRIGERATION CIRCUIT			
INDEX NO.	DESCRIPTION	MATERIAL OR MODEL NUMBER	PART NUMBER	REQ'D NUMBER			
				B-1 C-0	C-1		
19	CLAMP		P00752-01	2	2		
20	HOLDER - EXP.V		451267-01	1	1		
21	CLAMP		443461-02	1	1		
22	REDUCER	12.7x9.53	421904-01	1	1		
23	COPPER TUBE(A)-HIGH SIDE	COPPER TUBE-HIGH SIDE 377265G01	477647M01	1	1		
24	TEE	COPPER TUBE-HIGH SIDE 377265G01 6.35DIAx6.35DIAx6.35DIA	417394-01	1	1		
25	COPPER TUBE(B)-HIGH SIDE	COPPER TUBE-HIGH SIDE 369743G01	471437M01	1	1		
26	TEE	COPPER TUBE-HIGH SIDE 377265G01 6.35DIAx6.35DIAx8DIA	420041-03	1	1		
27	PRESSURE SWITCH	COPPER TUBE-HIGH SIDE 377265G01 SEP-P180HHD-1	459863-01	1	1		
28	CHARGE TUBE (B)	COPPER TUBE-HIGH SIDE 377265G01	428058-02	1	1		
29	COPPER TUBE(C)-HIGH SIDE		370087M01	1	1		
30	COPPER TUBE-LOW SIDE	COPPER TUBE-LOW SIDE 370088G01	370088M01	1	1		
31	INSULATION TUBE	COPPER TUBE-LOW SIDE 370088G01	H71030650	1	1		
32	COPPER TUBE(B1)-LOW SIDE	COPPER TUBE(B)-LOW SIDE 463016G01	463016-01	1	1		
33	CHARGE TUBE (B)	COPPER TUBE(B)-LOW SIDE 463016G01	428058-08	1	1		

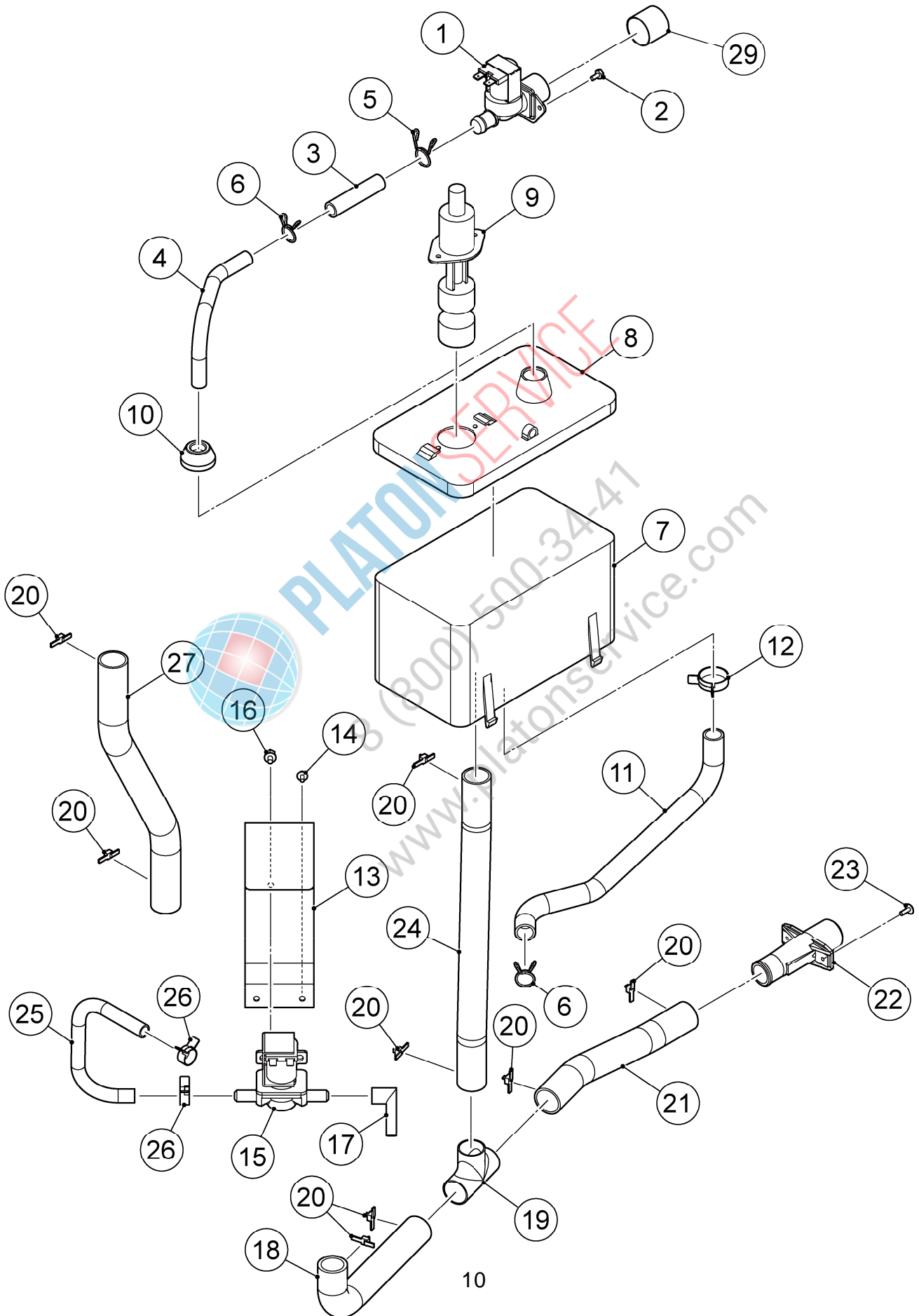

HE

MODEL: FM-170AKE(-N)		TITLE: D. WATER CIRCUIT					
INDEX NO.	DESCRIPTION	MATERIAL OR MODEL NUMBER	PART NUMBER	REQ'D NUMBER			
				B-1 C-0	C-1		
1	WATER VALVE		452993-01	1	1		
2	HEX HEAD BOLT		FBH0408S0	2	2		
3	SI HOSE		H11014060	1	1		
4	PIPE-WATER SUPPLY		477649M01	1	1		
5	HOSE CLAMP		435934-03	1	1		
6	HOSE CLAMP		435934-02	2	2		
7	RESERVOIR		232626-01	1	1		
8	COVER - RESERVOIR		232627-01	1	1		
9	FLOAT SWITCH		458279-01	1	1		
10	COVER - RESERVOIR INLET		415094-01	1	1		
11	HOSE(A)		350619-01	1	1		
12	CLIP BAND		423866-08	1	1		
13	BRACKET/WV		476458M01	1	1		
14	PAN HEAD MACHINE SCREW (SPRING WASHER AND FLAT WASHER)		FSK0408F0	2	2		
15	WATER VALVE		468655-01	1	1		
16	HEX HEAD BOLT (SPRING WASHER AND FLAT WASHER)		FBK0508F0	2	2		
17	DRAIN PIPE		460263-01	1	1		
18	HOSE(C)		475198G01	1	1		
19	TEE		120897M01	1	1		
20	TIE	CV-150	7920-0003	8	8		
21	PVC Hose - FSA		HD2226220	1	1		
22	DRAIN PIPE		321035-01	1	1		
23	T2 TRUSS HEAD SCREW		FT20410M0	2	2		
24	PVC Hose - FSA		HD2226350	1	1		
25	PVC Hose (Food Grade)		HD0912220	1	1		
26	CLAMP		423866-03	2	2		
27	PVC Hose - FSA		HD1923380	1	1		
29	CAP		417323-01	1	1		

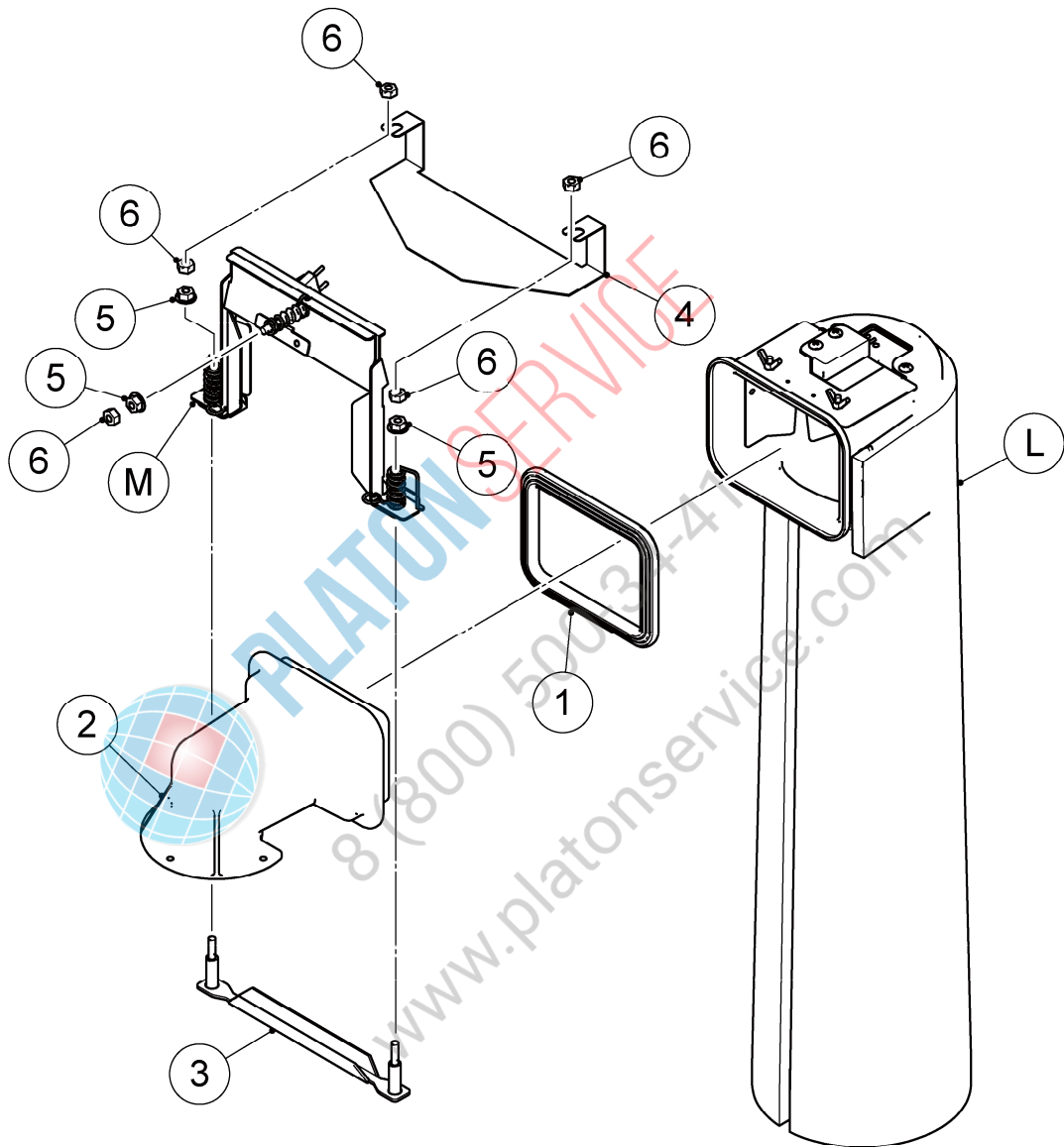

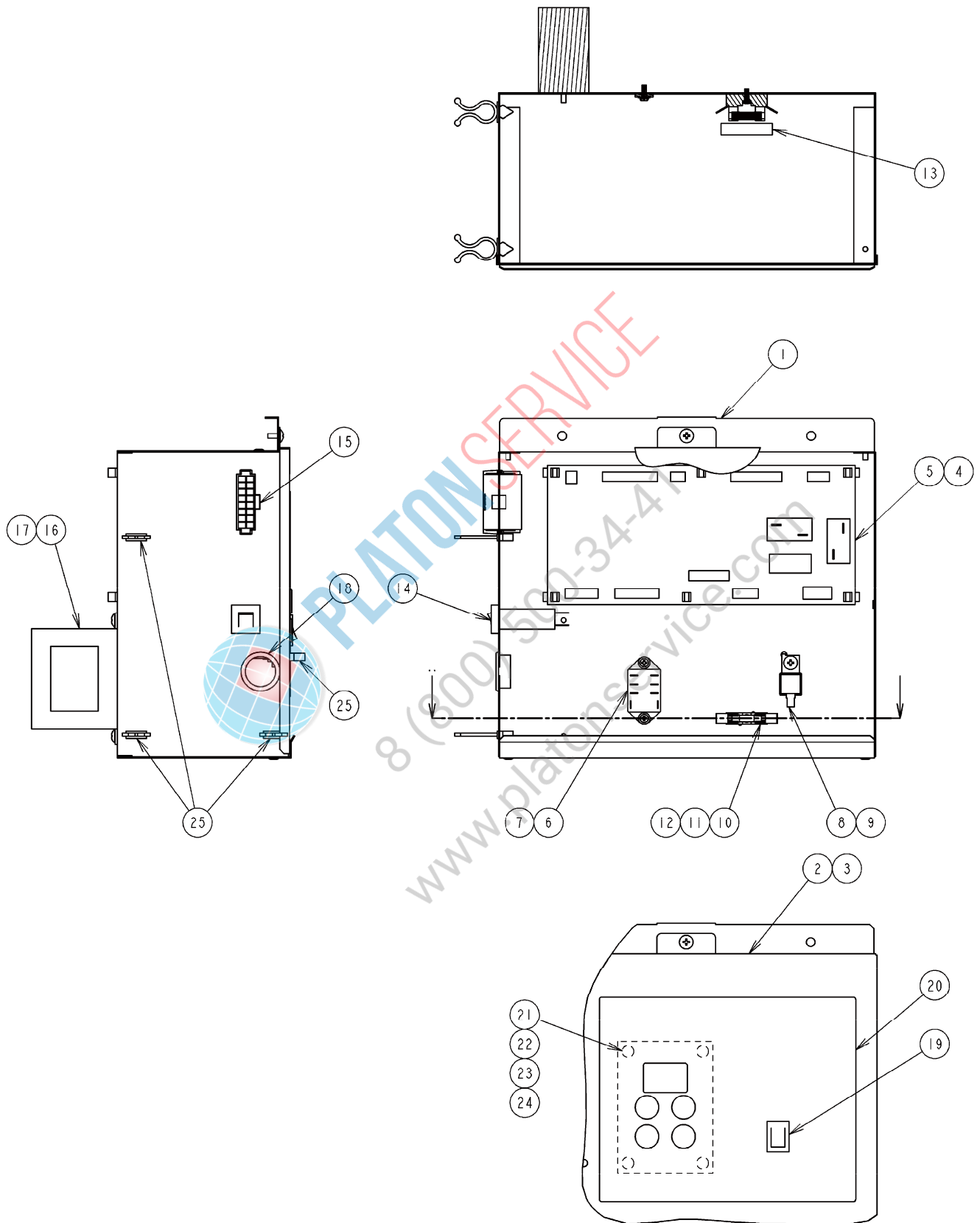

HE

MODEL: FM-170AKE(-N)		TITLE: F. CONTROL BOX ASSY					
INDEX NO.	DESCRIPTION	MATERIAL OR MODEL NUMBER	PART NUMBER	REQ'D NUMBER			
				B-1 C-0	C-1		
1	CONTROL BOX		122270G01	1	1		
2	COVER - CONTROL BOX		377266G01	1	1		
3	TRUSS HEAD SCREW		FST0408F0	1	1		
4	BOARD SUPPORT		414929-01	6	6		
5	CONTROLLER BOARD - 09CM		P01372-99	1	1		
6	RELAY		406132-08	1	1		
7	T2(S) FLANGED PAN HEAD SCREW		431415-01	2	2		
8	SUREGE ABSORBOR		436573-02	1	1		
9	TRUSS HEAD SCREW		FST0408S0	1	1		
10	FUSE HOLDER		4Y2547-01	1	1		
11	FUSE		451924-02	1	1		
12	PAN HEAD TAPPING SCREW T2		FT50308F0	1	1		
13	LABEL/FUSE		477494L01	1	1		
14	PROTECTOR		440972-01	1	1		
15	HARNESS (A)		377272G01	1	1		
16	TRANSFORMER		P02623-01	1	1		
17	T2 TRUSS HEAD SCREW		FT20408F0	2	2		
18	BUSHING		428394-05	1	1		
19	ROCKER SWITCH		460681-01	1	1		
20	CONTROL LABEL		374148L01	1	1		
21	SPACER		451658-05	4	4		
22	OPERATION BOARD - 09CM		P01373-01	1	1		
23	FLAT WASHER		FWPL03P0	4	4		
24	NUT		FNH103F0	4	4		
25	WIRE RETAINER	No.249	427902-03	4	4		

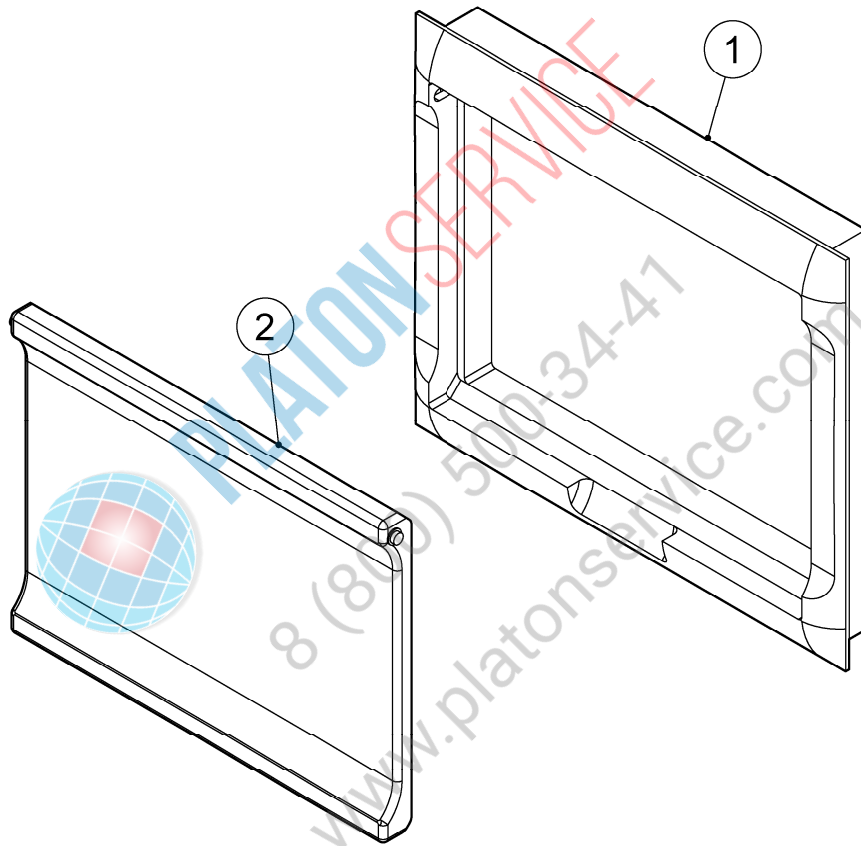

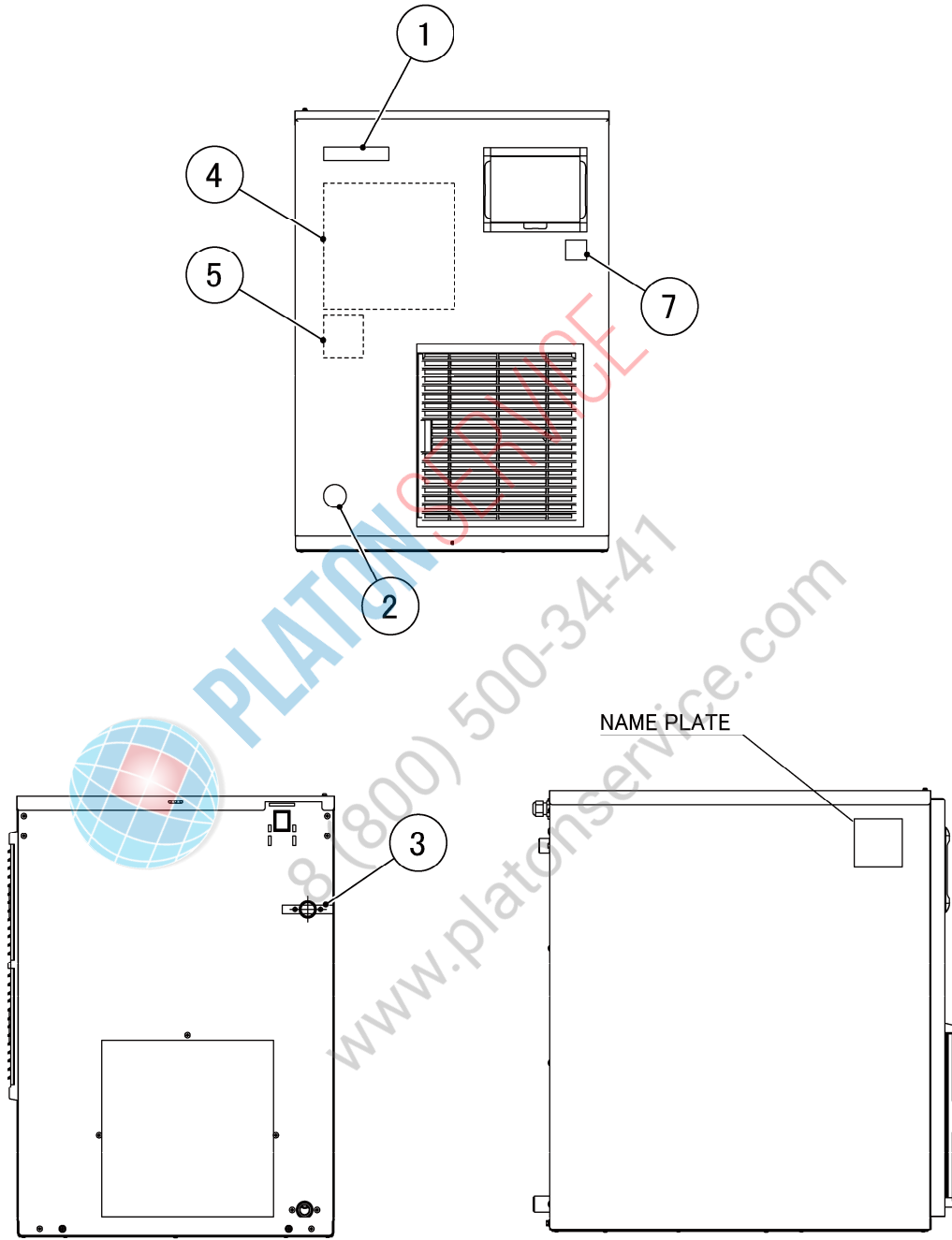

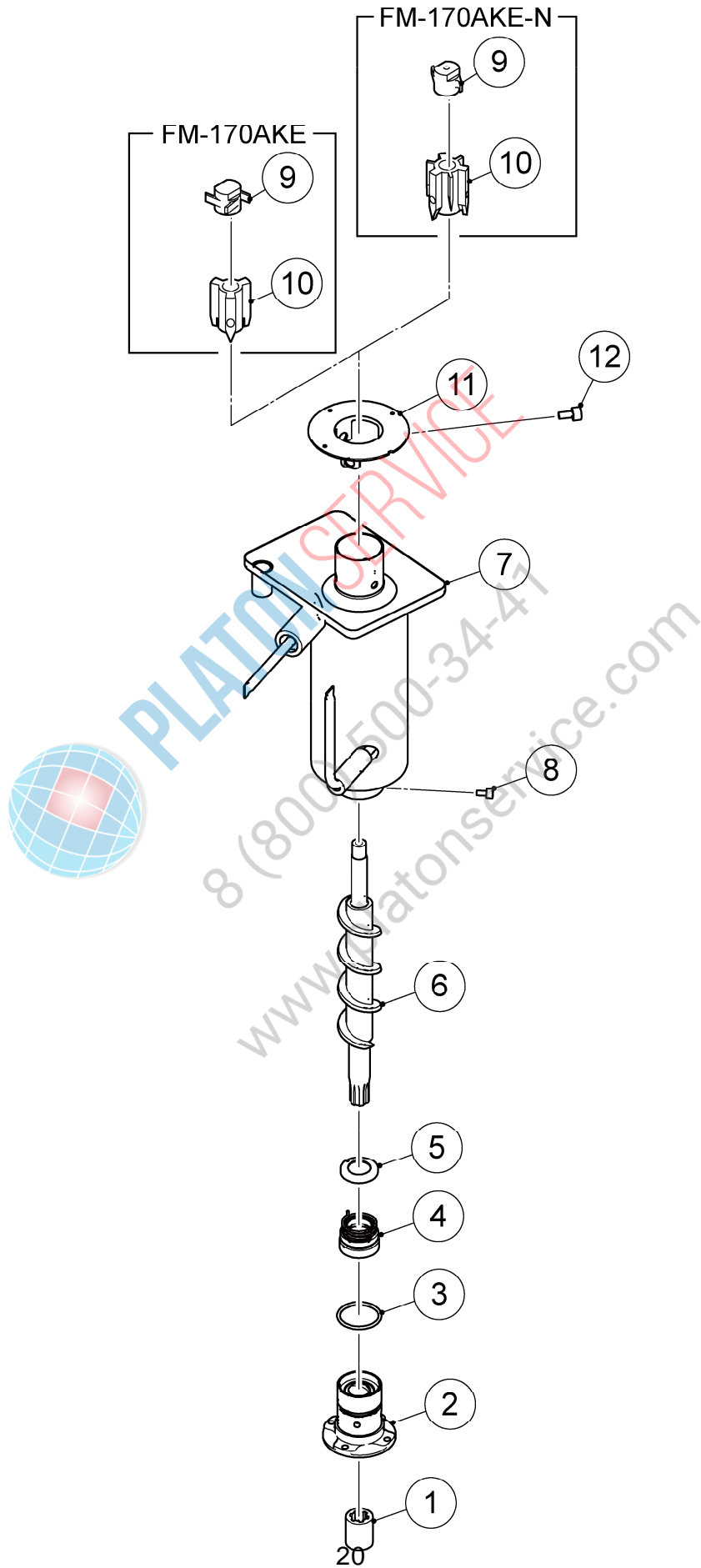

HE

MODEL: FM-170AKE(-N)		TITLE: J. EVAPORATOR ASSY					
INDEX NO.	DESCRIPTION	MATERIAL OR MODEL NUMBER	PART NUMBER	REQ'D NUMBER			
				B-1 C-0	C-1		
1	COUPLING-SPLINE ASSY		418316-01	1	1		
2	HOUSING		206013G05	1	1		
3	O RING	G40	7616-G040	1	1		
4	MECHANICAL SEAL	HK9A-MS 22 DIA	432491-01	1	1		
5	RING (B)		432494-01	1	1		
6	AUGER		361013G01	1	1		
7	EVAPORATOR		241041G02	1	1		
8	SCREW		P01718-01	4	4		
9	4 CUTTER		427137-01	1	1		
	CUTTER	F084-C106	440905-01	1	1		
10	EXTRUDING HEAD - 45F		327140G01	1	1		
	EXTRUDING HEAD(NUGGET)	F084-C106	327141G01	1	1		
11	FLANGE/45		464843-02	1	1		
12	SEALBOLT-M8		P01768-01	3	3		

